

Kartsport Canada

Book 2 Technical Regulations

To be read and applied in conjunction with
Kartsport Canada Regulations
Book 1 Sporting Regulations,
Rok Cup Canada Regulations,
Briggs & Stratton Canadian Regulations,
where applicable

Effective April 1, 2020

Contents

1.	These Technical Regulations	5
2.	Parts, Components, Measurements	5
3.	Equipment Entry Regulations	6
3.1	Briggs & Stratton and ROK have their own technical specifications.....	6
3.2	Repairs or Replacement After Technical Marking.....	6
3.3	Exchanging of Equipment	7
4.	Pre-Race Technical Inspection	7
4.1	Technical Inspection Self-Declaration	7
4.2	Technical Inspection Sticker	7
5.	Technical Marking Protocol	8
5.1	Responsibility for Marking and Sealing.....	8
5.2	Pre-Race Component Marking and Sealing.....	8
5.3	Parc Fermé Component Marking	8
6.	Post-Race Technical Inspection	8
7.	Technical Rules for Wet Racing.....	9
8.	General Kart Specifications	10
8.1.	Eligible Chassis	10
8.2.	Main Frame Construction	10
8.3.	Roll Cages.....	11
8.4.	Overall Measurements.....	11
8.5.	Chassis Suspension.....	11
8.6.	Driver Position	11
8.7.	Floor Pans.....	12
8.8.	Steering Linkage Mechanisms.....	12
8.9.	Steering Shafts	12
8.10.	Steering Wheels and Hubs	12
8.11.	Brake Systems	13
8.12.	Front Wheel Retention	13
8.13.	Rear Axles.....	14
8.14.	Wheel Hubs.....	14
8.15.	Wheels	14

8.16.	Driver's Seat	15
8.17.	Front and Side Bumpers.....	15
9.	CIK-FIA Drop-Down Front Fairing	17
10.	Rear Protection	17
10.1.	Plastic Rear Protection	17
11.	Ballast Weight Mounting	19
12.	Fuel Tank and System.....	19
13.	Clutches.....	19
14.	Chain/Oil Guard	19
14.1.	Chain Oilers	20
15.	Changing Ratios.....	20
16.	Competition Numbers and Number Panels	20
17.	Instrumentation and Communication	21
18.	Throttle Return Spring	21
19.	Seat Belts and Mirrors	21
20.	Hand Controls	21
21.	Transponder.....	22
21.1.	Transponder Mounting Location.....	22
22.	Driver's Name	22
23.	Starter Batteries	23
24.	Airflow Control On Radiators.....	23
25.	Tires	23
25.1.	Tire Specifications	23
25.2.	Tires For Use in Dry Track Conditions	23
25.3.	Tires For Use in Wet Track Conditions	24
26.	Bodywork Specifications	24
26.1.	Components - Materials and Usage.....	24
26.2.	CIK Bodywork Specifications	24
26.3	Bodywork Regulations: Side Pods	24
26.4	Bodywork Regulations: Nose Cone.....	25
26.5	Bodywork Regulations: Steering Column Fairing.....	25
26.6	CIK-FIA Bodywork Dimensions	26
27.	Loose or Lost Components	26

28.	Mini60, OKJ, OK, KZ, KZ2 Class Preparation	27
29.	Rok Mini, Junior, Senior, Shifter and Shifter Masters	27
32.	Briggs & Stratton Cadet, Junior Lite, Junior, Senior and Masters	27
33.	All Other Classes	27
34.	Fuel and Oil Requirements	27
34.1.	Source and Communication	27
34.2.	Fuels Required for Certain Classes	28
34.3.	Lubricant Oils	28
35.	Fuel and Oil Testing	28
36.1.	General Conditions.....	28
36.2.	Fuel Checking Procedure.....	28
36.3.	Testing Four Cycle Fuel and Oil	29
37.	Use of Cameras on Karts.....	29
37.1.	Camera Mounting Positions Four-Cycle.....	29
37.2.	Camera Mounting Positions Two-Cycle	29
37.3.	Camera Mounts	30
37.4.	Permitted Cameras	30

1. These Technical Regulations

In determining questions of eligibility of a kart, or the presence, absence or condition of a component of a kart, Officials shall be guided by the principle:

"If the Regulations do not state that you can do it, you cannot"

"A claim of lack of knowledge in the event of a kart being found ineligible, will not be considered."

The Spirit and Intent will be the standard by which these Regulations are enforced.

Compliance with these Technical Regulations does not necessarily ensure eligibility of karts by other sanctioning bodies.

Should doubt exist in the mind of a competitor, manufacturer, distributor, or Official as to the interpretation or application of these Regulations, the competitor, manufacturer, distributor, or Official is encouraged to first communicate in writing, by fax or email to Kartsport Canada. Verbal inquiries will not be considered.

It is the entrant and/or driver's responsibility at all times to ensure the ongoing compliance with mechanical safety and chassis, bodywork and engine technical eligibility of the kart.

Out of compliance parts, equipment or configuration on the kart, are not deemed to have been authorized or approved by reason of having passed through the inspection process at any time or any number of times.

Clubs and Series may adopt these Technical Regulations for use within their own organization. Clubs and Series are encouraged to appoint a Technical Inspector and Assistants.

2. Parts, Components, Measurements

All replacement parts are subject to these Regulations. Any part, hole, shape, dimension, measurement or appearance not listed in these Regulations does not exclude it from inspection.

Production changes by the manufacturer of an engine, kart or part for a kart, or manufacturer of an aftermarket part causing any part not to conform to the specifications, or not to conform with the Spirit and Intent of these Regulations are subject to a decision by the officials, as to whether or not the part will be considered eligible and permitted for use in competition.

Manufacturer's manuals are part of the equipment specifications and may be used to reference eligibility of components.

Systems for the measuring of the maximum engine revs and/or the control of the clutch functioning may be used in categories where engine speed limits and/or limits regarding clutch functioning are prescribed. They shall be installed in the strict respect of the relevant instructions.

On the decisions of the Steward(s), the Technical Inspector will be authorized to interchange an Entrant's ignition system for the system supplied by the event organizer. The substitute ignition system to be of the same make and model as the one used by the Entrant concerned.

3. Equipment Entry Regulations

3.1 Briggs & Stratton and ROK have their own technical specifications.

Rok Cup Canada Regulations:

http://www.vortex-rok.com/championship_engines.php?anno=2019&n=Canada&ID_campionato=40,61,98,120,128,172,237,269

Briggs & Stratton Canadian Regulations:

https://www.briggsracing.com/sites/default/files/content/files/briggs_2020_206_rules_canada_final.pdf

Two engines and one chassis are permitted for each entry and must be noted by serial number(s) on the Technical Self-Declaration form. Unless stated otherwise in a club or series supplementary regulations.

Changing chassis may occur only if there is physical damage (to be considered un-repairable or broken) upon approval by the Technical Inspector. Changing chassis may subject a driver to start the next session or race from the rear.

Changing to the second declared engine may occur only if there is physical damage upon approval by the Technical Inspector. Changing engines may subject a driver to start the next session or race from the rear.

3.2 Repairs or Replacement After Technical Marking

Rok Classes: Repair and/or replacement must be in accordance with Rok Cup Canada Regulations

Briggs & Stratton: Repair and/or replacement must be in accordance with Briggs & Stratton Canadian Regulations

Repairs requiring the breaking of a seal or loss of a mark or changing of a chassis must be accomplished under the Scrutiny of a Technical Inspector. The appropriate parts must re-sealed or re-marked and the entrant must start at the rear of the grid.

Cleaning of carburetors is permitted in Four-Cycle classes. The cleaning must be approved by, and accomplished under, the scrutiny of a Technical Inspector. The appropriate parts must be re-marked with the entrant retaining their position on the starting grid.

A valve cover gasket that has oil leakage or a valve cover that is damaged in a manner that could cause oil leakage may be replaced. The replacement must be approved by and accomplished under the scrutiny of a Technical Inspector. The valve cover must be re-marked with the entrant retaining their position on the starting grid.

At any time during the event the entrant will not lose their starting position for the next session or the Final Race when any of the following procedures are accomplished under the scrutiny of the Technical Official, and the exhaust header retainer is re-sealed:

Replacement of a broken, kinked, or cracked header. Re-tightening of the header retainer nuts.
Replacement of a stripped exhaust header stud or bolt. Repair of the exhaust threads in the head.

A cracked header must still be in a condition that will pass all post-race Technical Inspection. If not, the entrant is excluded.

A broken header will pass post-race Technical inspection provided that the entire header/silencer is still

attached to the Kart by the support brace and/or the tether, and the entire exhaust system is in compliance with the Regulation. If the header and silencer are separated and cannot be presented to Technical inspection as a complete unit, the entrant is excluded.

3.3 Exchanging of Equipment

There shall be no exchanging of tire(s), engine(s), or chassis between entrants. If an entrant is competing in more than one class, there shall be no exchanging of tires between classes. Drivers may only use equipment listed on their Technical Inspection Self-Declaration.

In all classes, if physical damage occurs to the engine(s) listed on the Pre-Technical Inspection Self-Declaration form or if a chassis has physical damage (non-repairable) that would prevent an entrant from competing, an unlisted replacement engine or replacement chassis may be used with the approval of the Technical Inspector prior to use. The change must be noted on the Technical Self-Declaration form. The appropriate parts must re-sealed or re-marked. An entrant using a replacement engine or chassis must start at the rear of the grid.

The penalties for unauthorized use of equipment include the following. If the infraction occurs in Qualifying, the driver to start at the rear of the first race. In Heat and Pre-Final races, a driver to be scored in last place and/or start at the rear in the next race. In Final races, the penalty is exclusion.

4. Pre-Race Technical Inspection

4.1 Technical Inspection Self-Declaration

It is the competitor's responsibility to ensure that their kart meets the technical requirements for the class through the entire race event. Drivers found on the track from qualifying or the designated time without having completed and submitted a Pre- Technical Inspection Self-Declaration form are subject to penalty. Drivers who enter Post-Race Technical Inspection and are found to have not completed or submitted a Technical Self-Declaration form will be excluded.

Each participant must submit a fully completed Technical Self-Declaration form to the Technical Inspectors. The Technical Self-Declaration form must be submitted before qualifying session begin in any class or before a designated time.

Any changes required on the completed and submitted Technical Self-Declaration form must be completed and accepted by the Technical Inspectors before qualifying sessions begin in any class or before a designated time.

Any Kart, safety equipment or apparel is subject to Technical Inspection at any time. The Technical Self-Declaration form is retained by the Technical Inspector.

4.2 Technical Inspection Sticker

The event organizer may provide a unique Technical Inspection sticker for each event. The sticker shall be water resistant and have a space large enough for the competitors two or three digit kart number. The participant must attach the sticker to the designated location on the appropriate kart before it is allowed to enter the track for any session.

5. Technical Marking Protocol

5.1 Responsibility for Marking and Sealing

It is the responsibility of the driver to ensure that their entry has been properly marked or sealed for competition and Technical Inspection (engine, tires, and chassis where required) at any time during the competitive portion of the event. Failure to do so may cause penalty, as determined by the Steward(s) or Clerk of the Course.

5.2 Pre-Race Component Marking and Sealing

- a. The engine, tires and chassis used by a driver in qualifying may be marked or sealed by a Technical Inspector at a designated time and place before, during, or after the qualifying session before the driver and/or mechanic or Kart leaves the weigh-in area after qualifying.
- b. Dependent upon class, all engine and chassis markings must either form a seal from one part to another or be an identifying mark.
- c. All tires must have been marked on the inner sidewall in a manner determined by a Technical Inspector at some time before leaving the weigh-in area after qualifying. Serial numbers may be recorded as the unique identifiable mark.
- d. Latex paint is recommended for engine marking.

5.3 Parc Fermé Component Marking

When a Parc Fermé is used, all tires, fuel tanks, and fuel supply reservoirs shall be marked with the competition number of the entrant, at a determined time, before qualifying.

6. Post-Race Technical Inspection

- a. At the conclusion of any track session, the Steward(s) and/or the Technical Inspector may select karts for inspection, and the competitors involved shall without delay take the selected karts directly to the Parc Fermé/Technical Impound/Inspection area.
- b. At the conclusion of a race all karts are deemed to be impounded and must remain in the exact condition in which they left the race track until released by the Steward(s) and/or Technical Inspector or designate.
- c. It is incumbent on the entrant/driver to determine whether or not their kart has been selected for inspection by reporting immediately to the Parc Fermé/Technical Impound/Inspection area for inspection or release by the Technical Inspector or designate.
- d. Failure to present the kart promptly at the Parc Fermé/Technical Impound/Inspection area when requested may result in a penalty. Penalties include, a fine, being scored in last place and/or starting at the rear of the grid for the first/next race or exclusion. Any such penalty is not subject to protest or appeal.
- e. One entrant/driver and/or one mechanic must attend each kart at the Parc Fermé/Technical Impound Inspection Area. Technical inspection may begin on a kart or engine without the entrant/driver and/or mechanic being present.

- f. In addition to the vehicle and its components, anything mounted on or in a kart may be impounded by the Steward(s) or Technical Inspector.
- g. The entrant/driver is responsible for all costs, if any, associated with the teardown, inspection and rebuilding of any component(s) selected for eligibility verification by the Steward(s)
- h. A qualifying position or a race finishing position, and any Club or Series points and other awards available to a competitor that is subjected to an eligibility verification, may be withheld until the results of any inspection are determined.
- i. The entrant/driver is responsible for ensuring that the kart is returned to proper operating condition after any impound or inspection by the Technical Inspector or support personnel. Protests will not be allowed in this regard.
- j. Technical inspection begins when the inspector checks the eligibility of the engine and tires. If any seals are broken or missing, or tires or chassis ineligible, then the entrant/driver will receive a penalty. Penalties include being scored in last place and/or starting at the rear of the grid for the first/next race or exclusion. The engine or other components may still be inspected as determined by the Technical Inspector. If the seals are unbroken and present a detailed engine inspection should begin to a level determined by the Technical Inspector.
- k. If, at any point during the inspection, an engine or other components are found to be in contravention of these Regulations, the inspection may proceed at the discretion of the Technical Inspector. The Technical Inspector will notify the Steward(s) of the technical infraction by the entrant/driver and the Technical Inspector can retain the part(s) in question. If the entrant wants the part(s) in question to be returned the entrant waives all right to protest the decision of the Technical Inspector and/or Steward(s). If the entrant/driver refuses to surrender the part(s) in question the entrant/driver will be excluded from the results and no protest can be submitted.

The Technical Inspector shall label the impounded racing equipment and one of these officials will be responsible for providing the impounded racing equipment at an appeal hearing if called.

- l. The Technical Inspector may use any tool(s) required for the inspection.
- m. If a technical infraction is found, the findings of the Technical Inspector must be immediately communicated to the Steward(s). The Steward(s) will determine if a penalty will be applied and the severity of the penalty based on the circumstances of the violation. Refer to the KartSport Canada Sporting Regulations - Standard Karting Penalties chart for penalty guidelines.
- n. Post-Race Technical Infractions can be either Pre-Race Technical Inspection or Equipment related. The penalties for deviations from the Technical Self-Declaration include monetary fines, position penalties or exclusion at the discretion of the Steward(s).

7. Technical Rules for Wet Racing

Once a race has been declared Wet; The choice of wet or dry tires will be decided by the individual driver.

When a race is declared Wet, all Technical Regulations will be adhered to, except as follows:

- a. If wet tires are to be used, they are defined as any production type tires that have been manufactured by any Kart tire manufacturer specifically for wet weather conditions.

- b. Specified manufacturers and compounds of tires may be required. A competitor may not mix and match tires from different manufacturers or different designations or compounds.
- c. Modified, grooved or otherwise altered dry condition tires are not acceptable.
- d. The rear wheels may be moved inward, to narrow track width to the limit permitted in the Technical Regulations for minimum width, but the axle ends may not protrude beyond a plane drawn across the outer face of the rear wheel.
- e. Rear protection or the rear bumper must have an overall width not exceeding the rear track width of the kart at any time, measured outside the rear wheels or tires, whichever is the greater, during both Dry and Wet conditions.
- f. A deflector may be added to the air filter on four-cycle engines provided that such additions do not provide a ram-air effect.
- g. Front and rear wet rims and tires must be used at their appropriate locations.
- h. In Rok classes, a rain deflector may be added to prevent water from entering the intake silencer. The deflector must be constructed of non-metallic material and securely attached to the chassis frame and/or metal side bumper bars. There can be no modifications or attachments whatsoever to the plastic side pods.

8. General Kart Specifications

8.1. Eligible Chassis

- a. In the Rok Cup classes, only chassis allowed by the Rok Cup Canada Regulations are permitted.
- b. For all other classes, eligible chassis include those homologated/registered by the CIK-FIA and any chassis that in the opinion of event Official(s) and Technical Inspector reasonably meet the intent and technical requirements of these regulations. Decisions regarding technical eligibility and compliance in all classes are reserved for the event Official(s) and Technical Inspector.
- c. Decisions made on chassis eligibility are final and are not subject to protest or appeal.

8.2. Main Frame Construction

- a. In addition to compliance with the Spirit and Intent of the Rules, overall quality of workmanship is considered in the acceptance of a Kart presented for competition. Tubular steel construction is the only type of frame design method currently considered to be within the Spirit and Intent of the Rules of all classes.
- b. The frame must be made from magnetic structural steel or structural steel alloy.
- c. The centers of main frame rail tubes may be no higher than a line projected horizontally between the centers of the front and rear wheel hubs.
- d. Minimum tubing outer diameter: 1.000" (25.4 mm)
- e. Maximum tubing outer diameter: 1.400" (35.56 mm)

- f. Minimum tubing wall thickness for tubing 1.125" OD or less: 0.078" (1.98 mm)
- g. Minimum tubing wall thickness for tubing over 1.125" OD: 0.060" (1.53 mm)

8.3. Roll Cages

The addition of a roll cage to the kart chassis-frame is not permitted unless there is a class designation for roll cage equipped karts. Karts with roll cages are not permitted to run on a track at the same time as karts without roll cages.

8.4. Overall Measurements

Class	Minimum Wheelbase (Note 1.)	Maximum Wheelbase (Note 1.)	Maximum Overall Width	Minimum Kart Weight (Note 4.)
TWO CYCLE Classes including: Junior, Senior, Masters	101 cm	110 cm	140 cm	59 kg (130 lbs)
Mini Rok	89 cm	95 cm	120 cm	59 kg (130 lbs)
FOUR CYCLE Classes including Junior Lite, Junior, Senior, Masters	101 cm	110 cm	127 cm	59 kg (130 lbs)
Cadet	89 cm	95 cm	120 cm	59 kg (130 lbs)

Note 1. Wheelbase is measured between front and rear true axle centers.

Note 2. Minimum Kart Weight is less driver, fully equipped and race ready.

Minimum Track Width TWO CYCLE: A line passing through the outer edges of the front and rear tires, with the steering in straight ahead position, must be a minimum of 4cm wider than the appropriate side pod.

Minimum Track Width FOUR CYCLE: Each outer edge of the rear wheels may be a maximum of 2.5cm narrower than the outer width of the appropriate side pod.

Maximum Overall Length: Measured without front and/or rear bodywork is 182cm for all classes.

Maximum Overall Height: Measured from the ground to the uppermost part of the Kart, less driver, fully equipped and race ready is 65cm for all classes.

8.5. Chassis Suspension

The use of or attempt to create and/or conceal any suspension movement is prohibited. Normally, this includes springs, shocks, spring washers, grommets, etc. Approved torsion bars are not considered suspension.

8.6. Driver Position

When normally positioned on the Kart for racing competition, the entire driver shall be within the specified width and length dimensions of the Kart.

8.7. Floor Pans

The floor pan shall be of a design that will prevent any portion of the driver's body from passing between/below Kart components.

The floor pan must be made of rigid material that stretches only from the central strut of the frame to the front frame cross member of the kart, remaining within all confines of the chassis.

If it is perforated, the holes must not have a diameter of more than 10 mm and they must be apart by four times their diameter as a minimum.

8.8. Steering Linkage Mechanisms

All steering linkage must be of the direct, mechanical type.

All steering assembly fasteners must be either cotter-pinned, safety wired, secured by snap rings, or utilize self-locking nuts in original condition.

All bolts shall be at least Grade 5 or US Mark 3 of a minimum of 6 mm diameter. All rod ends must be universal type swivel joints.

8.9. Steering Shafts

Tiller/vertical shaft steering mechanisms are not allowed.

Steering shafts must be 18 mm minimum OD steel tubing of one-piece design, 1.8 mm minimum wall thickness, with a minimum 5/16" (8 mm) diameter fastener at the base.

8.10. Steering Wheels and Hubs

Steering must be controlled by a steering wheel which a continuous rim not incorporating any reflex angles in its basic shape. The upper and lower 1/3 of the circumference may be straight or of a different radius to the rest of the wheel. The rim must be manufactured with a metallic structure made of steel or aluminum.

The one-piece steering hub will be secured with a minimum 6mm diameter Grade 5 or US Mark 3, or 6 mm bolt and nut, perpendicular to the longitudinal centerline of the shaft.

It is recommended that the unthreaded portion of this bolt be long enough to clear both the shaft and the hub utilizing a washer(s), if necessary, to enable proper tightening.

Welding of the steering wheel to the hub is NOT allowed. Welding the steering wheel hub to the shaft is not allowed.

No shaft extensions are allowed.

Minimum steering wheel outer diameter is 25.4 cm.

The steering wheel must have a minimum of three spokes.

The steering wheel must be of closed loop design and circular, except that the upper and lower 1/3 of the wheel circumference may be flat.

Any device mounted on the steering wheel must not protrude by more than 20 mm from the plane forward of the steering wheel and must not have sharp edges. Flexible steering controls by cable or chain are forbidden. All parts of the steering must have a method of attachment offering maximum safety (split pins, self-locking nuts or burred bolts). The steering column must have a minimum diameter of 18 mm and a minimum wall thickness of 1.8 mm.

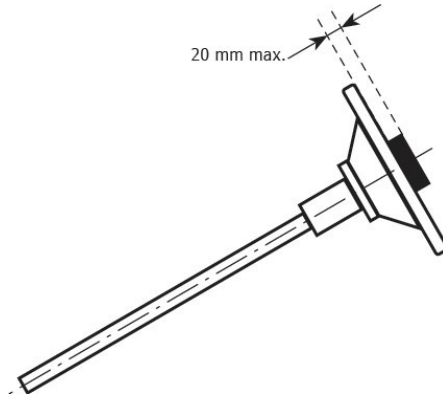

8.11. Brake Systems

All Karts, at a minimum, must be equipped with a braking system that brakes the rear wheels. Except for disc retention, fasteners related to the braking system must be secured with one of the following methods:

- Single nut with cotter pin or safety wire Double nuts
- Snap rings
- Self-locking nuts – metallic or plastic type
- Each fastener used for rear brake disc retention must be secured either by cotter pin, or safety wire, or snap ring(s), or utilize completely metallic locking nuts.

“Floating” front disc brake retention shall be as manufactured, or by self-locking nuts (metallic or plastic type), or by nuts that are cotter pinned, safety wired, or utilize snap rings.

Brake rotors shall have no cracks or major chips.

Brake pads must be of sufficient area and thickness for proper braking for the duration of the event.

Brake discs must be made from steel, stainless steel or cast iron. Carbon and ceramic brake discs are forbidden.

8.12. Front Wheel Retention

Chassis that are CIK-FIA homologated/registered or meet CIK-FIA requirements can have a self-locking style retention nut in original condition.

All front axle spindles that are manufactured to receive a cotter pin, safety wire or snap ring must have these items installed.

8.13. Rear Axles

Rear axles must be of one-piece design.

Axles must be constructed from a magnetic iron or steel based material. For example, aluminum, stainless steel, titanium, and carbon fiber axles are NOT allowed.

The following table lists the minimum cross sectional tube thickness at any point in a rear axle, except for key housings, or snap ring grooves at the outer extremities for all classes unless otherwise noted.

Rear Axle thickness according to outer diameter			
Maximum external diameter (mm)	Minimum thickness (mm)	Maximum external diameter (mm)	Minimum thickness (mm)
50	1.9	37	3.4
49	2.0	36	3.6
48	2.0	35	3.8
47	2.1	34	4.0
46	2.2	33	4.2
45	2.3	32	4.4
44	2.4	31	4.7
43	2.5	30	4.9
42	2.6	29	5.2
41	2.8	28	Full
40*	2.9	27	Full
39	3.1	26	Full
38	3.2	25	Full

*40mm diameter rear axles in four-cycle classes, minimum cross sectional tube thickness is 2.40mm.

8.14. Wheel Hubs

Wheel hubs must be constructed of metallic materials. Both rear hubs must be keyed properly to the rear axle.

8.15. Wheels

Wheel: defined as the assembly of a rim with a pneumatic tire, for the driving and/or propulsion of the kart.

Wheel Width: defined as the distance between the inner and outer extremities of the wheel. Maximum beading diameter is 5.0" (127 mm)

Maximum width of any front wheel is 135 mm.

Maximum width of any rear wheel in Cadet and Mini Rok is 135mm.

Width of any rear wheel in all other Four-Cycle classes is 175mm - 185mm when using Dry tires

Maximum width of any rear wheel in all other Two-Cycle classes is 215mm

The use of automatic pressure regulating valves is prohibited.

8.16. Driver's Seat

Only bucket type seats are permitted.

Seat must be of one-piece molded construction, with no add-on sections.

Seat must be in good condition.

The seat must securely locate the driver laterally and longitudinally.

The seat must be bolted securely and rigidly in at least four places to the frame without using any damping devices and must not be adjustable while the kart is moving.

No portion of the seat may be located rearward of a plane projected vertically from the back of the rear axle.

Seat height requirements (top of seat) are as follows, measured from the ground:

Cadet and Mini Rok	10.0" (25cm) minimum
Junior Classes	12.0" (30cm) minimum
All Other Classes	14.0" (35cm) minimum

Shape and size of seats may be modified providing that the complete pattern area of all four final mounting locations are all located in the unaltered portion of the seat.

8.17. Front and Side Bumpers

Front and side bumpers are compulsory. All bumpers must be made of magnetic steel. All bumpers must remain as originally manufactured.

All CIK-FIA Homologated chassis must conform to their appropriate CIK-FIA Homologations for front and side bumpers. The front, rear and side bumpers must be homologated with the corresponding bodywork.

All non-CIK-FIA homologated chassis must have bumpers that conform to with either 8.17.a) or to the CIK-FIA homologated bumper regulations described in 8.17.b). Due to their non-CIK-FIA status and/or age, some deviations may be allowed by the Technical Director that do not affect safety.

a. Front Bumpers:

The minimum outer diameter of the tubing is 15 mm (0.590").

All front bumpers must be, at some point in the horizontal section of any of the frontal contact portion of the bumper, present when measured at 15 cm to 22 cm from the ground, as raced.

The front bumper must be mounted vertically above the chassis front member and attached to it in up to

four places.

The upper bumper bar cannot extend beyond the lower bumper bar by a reasonable amount.

There shall be front and lateral protection. The bumper must not project beyond a line drawn through the outside of the front and rear wheels at hub height, with the front wheels in the straight- ahead position.

Side Bumper Bars for Non-CIK-FIA Homologated Chassis:

Side bumper bars must be constructed of minimum 18 mm diameter steel tubing, must be secured by minimum 6 mm diameter bolts, and must allow for secure mounting of side pods.

The overall length of the side bumper bar shall be a minimum of 400 mm, measured from the backside of the side bumper bar closest to the rear tire, in a straight line to where it attaches to the kart at the front.

The rear portion of the side bumper bar may not protrude laterally beyond the rear tire, unless otherwise noted.

b. Bumpers for CIK-FIA Homologated Chassis:

CIK-FIA Homologated karts must maintain their homologated bumper specifications.

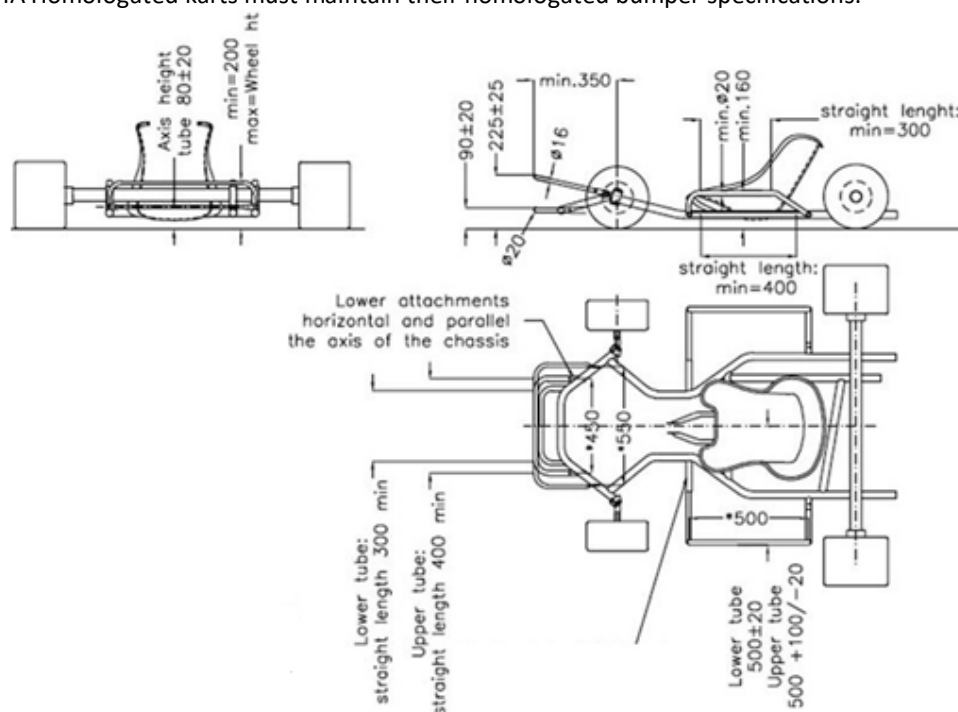

9. CIK-FIA Drop-Down Front Fairing

There is only one CIK-FIA homologated front fairing mounting kit (CIK-FIA Drawing 2c and homologation 1/CA/20 1/01 ET). The kit must be mounted as homologated, any modifications will be penalized.

If the Technical Inspector and/or Official(s) feel the part is damaged or modified it must be replaced prior to the next on track session.

From leaving the grid Entrants and/or Drivers are not permitted to touch the nose cone until they have cleared the post race inspection area or have been instructed otherwise by a Technical Inspector. Failure to do so may result in exclusion.

Entrants whose bumper has pushed back only on one side have not committed an infraction. If the bumper is pushed back on both sides, an infraction has occurred.

If an infraction has occurred a 3 position penalty is added to their session results. Officials may not vary the violation and penalties. Drop down penalties are not subject to protest.

10. Rear Protection

Rear protection is compulsory for all classes.

When the chassis used is a CIK-FIA homologated chassis that incorporates full-width plastic rear protection in the homologation, the homologated rear protection must be used as homologated.

Rear protection to have an overall width not exceeding the rear track width of the kart at any time, measured outside the rear wheels or tires, whichever is the greater.

Rear protection to cover at least 50% of each wheel/tire assembly at all times measured at the centre-line of the tire.

The construction of the rear protection must not present any danger as regards to safety.

10.1. Plastic Rear Protection

Chassis must be fitted with a full-width plastic rear protection and conform to the following specifications: Plastic rear protection must be made of molded plastic without foam filling, and the wall thickness must be constant in order to provide uniform strength.

Adjustable plastic rear protection is allowed in Four Cycle classes and Mini Rok where the track width is less than 136 cm.

It may under no circumstances be situated above the plane through the top of the rear tires.

The surface(s) of the rear protection must be uniform and smooth; the rear protection must not comprise holes or cuttings other than those necessary for its attachment and/or present at the homologation.

Gap between the front of the rear protection and the rear wheels' surface: 15 mm minimum, 50 mm

maximum.

Maximum width: that of the overall rear track width, at any time and in all circumstances.

Ground clearance: 25 mm minimum, 60 mm maximum in a minimum of 3 spaces of a width of 200 mm minimum, situated in the extension of the rear wheels and the center-line of the chassis.

It must have a minimum height of 200 mm above the ground and have at the rear a vertical surface (+0°/-5°) with a minimum height of 100 mm immediately above the ground clearance, measured in a minimum of 3 spaces of a width of 200 mm minimum, situated in the extension of the rear wheels and the center-line of the chassis (CIK-FIA Technical Drawing No. 2c appended Rear Protection attached herein as Appendix).

Rear overhang: 400 mm maximum.

The unit must be attached to the frame in at least 2 points by supports homologated with the protection and made of plastic, steel or aluminum (possibly by a supple system) on the 2 main tubes of the chassis, or on the currently used bumper (upper bar and anti-interlocking bar, Article 2.5.2), and it must be possible to install it on all homologated chassis (respecting the homologated F dimensions which vary from 620 to 700 mm).

In all conditions, the rear protection must at no time protrude beyond the external plane of the rear wheels.

Non-homologated chassis may be retrofitted with full-width plastic rear protection that is used on a CIK-FIA homologated chassis provided the original mounting points to the chassis are used and the minimum and maximum dimensions are followed.

CIK-FIA Technical Drawing No. 2c appended Rear Protection attached herein as Appendix). Drawing No. 2c does not apply to Four Cycle classes and Mini Rok where the track width is less than 136 cm.

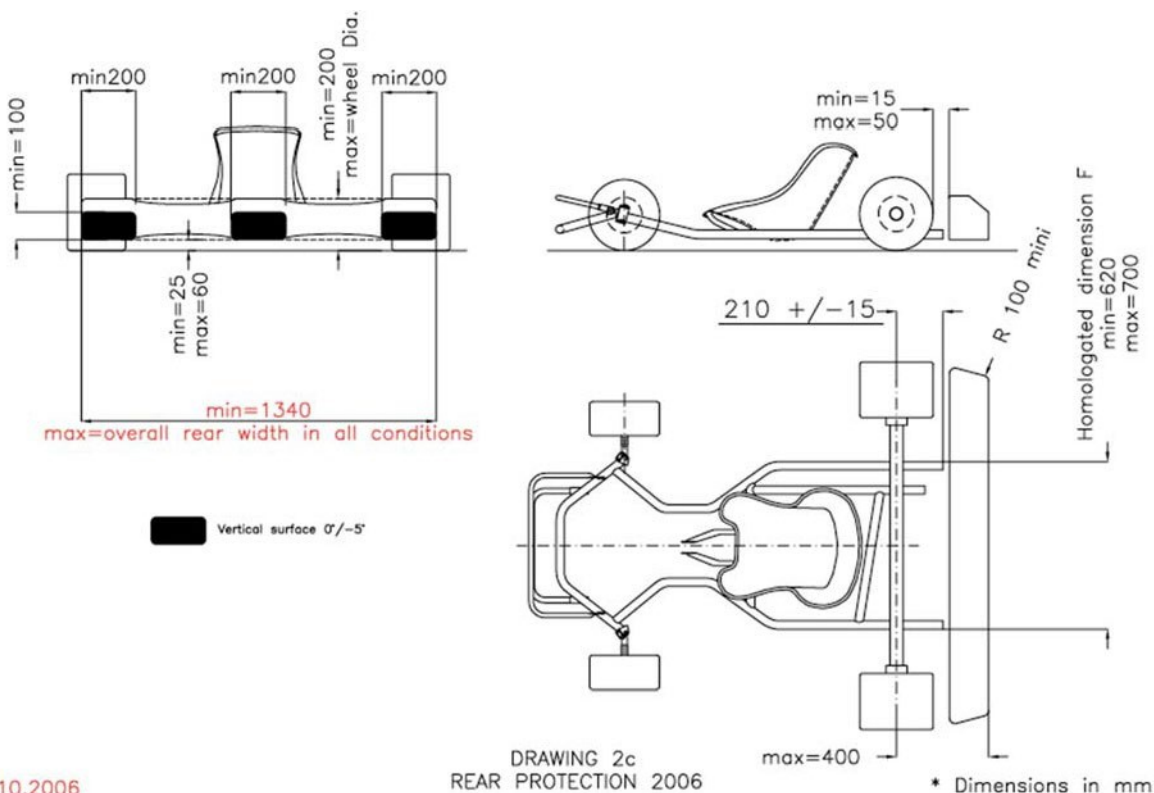

20.10.2006

11. Ballast Weight Mounting

Ballast weight must be securely attached to the main Kart frame or seat. Mounting of ballast weight on bumpers or side bumper bars is not permitted. Bolts must be used to secure the ballast weights. Attaching bolts must be no less than 5/16" (8 mm) in diameter.

A minimum of one attaching bolt is required for each 5 pounds of weight added. Attaching bolts must be securely fastened with one of the following methods:

- Single nut with cotter pin or safety wire
- Double nuts
- Self-locking nuts – metallic or plastic type

Large area washers must be used in the attaching of weights to the seat of the Kart, both inside the seat and outside of the ballast.

12. Fuel Tank and System

The fuel tank must be securely fixed to the chassis and be designed in such a way that neither it nor the fuel lines (which must be flexible) present any danger of leakage during the competition.

Fuel line length is limited to a length sufficient to connect the fuel tank to the fuel pump and the fuel pump to the carburetor.

A quick attachment to the chassis is strongly recommended.

The tank shall in no way be shaped to act as an aerodynamic device.

The tank must supply the engine only under normal atmospheric pressure (this means that, apart from the fuel pump located between the fuel tank and the carburetor, any principle or system, mechanical or not, which may have an influence on the internal pressure of the fuel tank is forbidden).

It is mandatory to place the tank between the main tubes of the chassis-frame, ahead of the seat and behind the rotation axis of the front wheels.

13. Clutches

Two-Cycle Classes: Refer to Rok Cup Canada regulations.

Four-Cycle Classes: Refer to Briggs & Stratton Canadian Regulations for clutch eligibility.

14. Chain/Oil Guard

Chain driven Karts must be equipped with a robust chain/oil guard.

The guard should be constructed of metal or plastic material, and securely mounted so as to not fall out of line with the chain.

The guard should extend around the axle drive sprocket to at least below the horizontal centerline of the sprocket, and must cover the chain as viewed from directly above.

Loosely mounted guards tied to the chassis may not be accepted.

A chain/oil guard which is not in its proper position during a race may cause the entrant to be given a mechanical defect flag, at the discretion of the Race Director and/or the Steward(s) and/or the Technical Inspector if it is considered a hazard.

If a chain/oil guard is noticed to be improperly positioned, or is improperly fastened, on a Kart other than during a race, the entrant will not be allowed to compete until it is repaired.

Fully enclosed chain guards, shown on right, are recommended.



14.1. Chain Oilers

Chain oilers are not permitted.

15. Changing Ratios

Transmission, gearbox, differential, torque converter or other device that permit a change of drive ratio while the vehicle is in motion is not permitted, unless otherwise specified.

16. Competition Numbers and Number Panels

All competitors must use solid black numbers on a square shape bright yellow background. The number(s) shall be bordered by the contrasting background by no less than 2 cm minimum.

In each class each kart must have a unique number with a maximum of three digits (2 – 999) made up of numerals (1, 2, 3 etc.) only. No letters (A, B, C etc.) will be allowed.

Each numerical digit must be at least 15 cm (6-inches) high with a 2 cm (3/4-inch) thick stroke using an Arial type or similar font.

Four number panels with numbers must be displayed on each kart.

One located at the front/center of the kart, the numbers visible from the front, mounted the steering column fairing.

One located on each vertical side pod/panel, as close as possible to the rear wheels.

One located on the rear of the kart visible and readable, from a position behind the Kart.



If number plates are used they must have rounded corners (diameter of rounded corners 15 to 25 mm), be flexible and made of opaque plastic. They shall always be visible (fixation without a possible displacement).

17. Instrumentation and Communication

- a. Definition of Data Acquisition: Any system, with or without a memory, installed on a Kart, enabling the driver or their team during or after an on track session to read, indicate, acquire, record or transmit any information.
- b. Definition of Telemetry: Data transmission between a moving Kart and an external body.
- c. Data acquisition during qualifying, heats and races is limited to systems with or without memory that permit the reading of only the following parameters: engine revolutions (by induction on the spark plug HT cable), two indications of engine temperature, the speed of one wheel, one x/y accelerometer, lap times, engine hours, global position satellite sensing. Systems capable of more than the specified input channels must have all channels other than those allowed disconnected or disabled.
- d. Any system of telemetry is forbidden for the entire event.
- e. Any radio, electronic, or verbal communication between any driver on the track and any other body is forbidden.
- f. Beacons used only to trigger on-kart systems are not considered telemetry and may be used. They must be placed in a location as directed by the Race Officials.
- g. Track strip sensing devices are not considered telemetry when used solely as a trigger for Official timing and scoring, and/or personal on-kart lap timing.
- h. The power supply for Data Acquisition Systems may come directly from an onboard battery in classes that allow or require an onboard battery for starting the kart.

18. Throttle Return Spring

All karts must be equipped with a positive acting throttle return spring.

19. Seat Belts and Mirrors

Seat belts, rear view mirrors, rear view devices or driver restraint systems (seat belts) are prohibited.

20. Hand Controls

On application to the Club or Series, permission may be given for the fitting of brake and throttle hand controls.

21. Transponder

Competitors are responsible to purchase their own transponder mount that attaches the transponder to the kart. Mounts are available at most tracks.

For all practice, qualifying and race sessions, it is the responsibility of the driver to assure that an event-registered AMB-compatible transponder is fitted prior to entry to the track.

It is recommended that competitors purchase their own transponder.

21.1. Transponder Mounting Location

The competitor is responsible for securing the scoring transponder to the kart to prevent loss of the transponder. The transponder must be mounted on the center of the rear of the driver seat. Minor offset from the center of the seat is permitted.

The transponder must be mounted vertically (inscription readable normally) with the center of the transponder installed 25 cm +/- 5 cm from ground level.

The space, in a straight line, between the transponder and the ground must be free, i.e. no lead, chassis tubing, battery or other element which can block the signal between the transponder and the detecting loop.

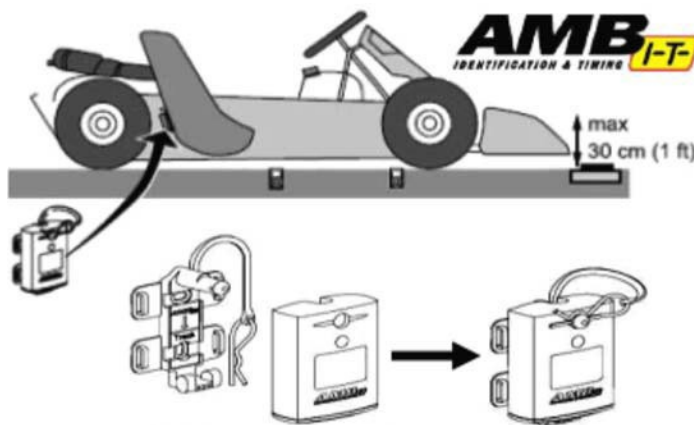

22. Driver's Name

It is recommended that the driver's name with the Canadian flag be on each side of the kart on the vertical portion of the side bodyworks. It is recommended that the height of the black letters of the driver's name and the flag shall be 3 cm minimum on a white background.



23. Starter Batteries

In classes that allow or require an onboard battery for starting the kart the specified battery must be mounted in the kart at all times. Only sealed, leak proof (maintenance free) batteries are allowed to feed the starter.

24. Airflow Control On Radiators

Devices to control airflow to radiators must conform to Rok Cup Canada Regulations.

If tape is used it must be continuous and wrap totally around the radiator either horizontally or vertically. Tape may not be removed while the kart is on track. No pull-off tabs allowed.

25. Tires

25.1. Tire Specifications

Clubs or Series reserve the right to designate specific tires, with regard to manufacturer name, compound, size, etc.

Tires in competition and practice must be pneumatic, designed for racing applications only. Radial tires are not permitted.

Maximum bead diameter is 5.0 inches.

Maximum outer diameter of all tires: Front 280 mm, Rear 300 mm. Minimum outer diameter of all tires is 225 mm.

Tires used must be CIK-FIA homologated unless specified otherwise in the Supplementary Regulations.

Any modification of a tire is forbidden. The treating of any tire with any chemical substance or by temperature alteration is forbidden.

Wet and Dry tires may not be mixed on the kart during any on track session.

Rear tire sizes must be used only on the rear of the kart. Front tire sizes must only be used on the front of the kart. Except in specified classes.

25.2. Tires For Use in Dry Track Conditions

For Qualifying, Pre-Final and Final races, competitors may only use one set of four dry tires.

25.3. Tires For Use in Wet Track Conditions

For Qualifying, Pre-Final and Final races, competitors may only use one set of four wet tires.

26. Bodywork Specifications

26.1. Components - Materials and Usage

- a. Required bodywork components are: One steering column fairing, one nose cone, two side pods, and associated mounting brackets and rear wheel protection as required in their Homologation.
- b. The combination of CIK-FIA Homologated bodywork (side pods, nose cone, steering column fairing) of different makes or models is authorized. Both side pods must utilize their respective homologated side bumpers and must be used as a matched set. The nose cone must utilize its respective homologated front bumper.
- c. Nose cone and side pods must remain attached at their normal attachment points to the Kart after the completion of any session/race.
- d. Nose cones must be attached to the Kart with the appropriate Homologated apparatus. Any form of reinforcement such as clamps, nuts/bolts, tie wraps, tape, wire, etc., is not allowed.
- e. No element of the bodywork may be used as fuel tank or for the attachment of ballast.
- f. Plastic used for the bodywork must not be able to splinter, shall have no sharp angles and shall not be made of Plexiglas-type materials.
- g. No cutting of bodywork elements is allowed.
- h. No attachments to bodywork are allowed except for decals and allowed cameras and mounts.

26.2. CIK Bodywork Specifications

All chassis must have CIK-FIA Homologated bodywork.

All CIK-FIA Homologated chassis must have CIK-FIA Homologated bodywork as required for the particular chassis.

26.3 Bodywork Regulations: Side Pods

The side pods must under no circumstances be located above the plane through the top of the front and rear tires (with the front wheels in the straight-ahead position).

In 2 cycle classes, side bodywork may not be located outside the plane drawn through the external part of the front and rear wheels (with the front wheels in the straight-ahead position).

In 4 cycle classes, side bodywork may be located outside the plane from the external part of the front to the

rear wheels by a maximum of 2.5 cm.

They may not be located inside the vertical plane through the two external edges of the wheels (with the front wheels in the straight-ahead position) by more than 40 mm.

They must have a ground clearance of 25 mm minimum and of 60 mm maximum.

The surface of the side bodywork must be uniform and smooth; it must not comprise holes or cuttings other than those necessary for their attachment.

Gap between the front of the side bodyworks and the front wheels: 150 mm maximum. Gap between the back of the side bodyworks and the rear wheels: 60 mm maximum.

No part of the side bodywork may cover any part of the Driver seated in his normal driving position. The side bodyworks must not overlap the chassis-frame seen from underneath. They must be solidly attached to the side bumpers.

On their outer rear vertical surface close to the rear wheels there must be a space for competition numbers.

26.4 Bodywork Regulations: Nose Cone

Nose cone must remain attached at the normal attachment points to the Kart after the completion of any on track session or race.

Nose cones must be attached to the Kart with the appropriate homologated apparatus. Any form of reinforcement such as clamps, nuts/bolts, tie wraps, tape, wire, etc., is not allowed.

Minimum width is 1,000 mm and its maximum width is as homologated.

26.5 Bodywork Regulations: Steering Column Fairing

It must not be located above the horizontal plane through the top of the steering wheel.

It must allow a gap of at least 50 mm between it and the steering wheel and it must not protrude beyond the nose cone.

It must neither impede the normal functioning of the pedals nor cover any part of the feet in the normal driving position.

Its width is 250 mm minimum and 300 mm maximum.

Its lower part must be solidly attached to the front part of the chassis-frame directly or indirectly. Its top part must be solidly attached to the steering column support with one or several independent bar(s).

A space for competition numbers must be provided.

CIK-FIA Homologated Karts must maintain their homologated bodywork specifications.

26.6 CIK-FIA Bodywork Dimensions

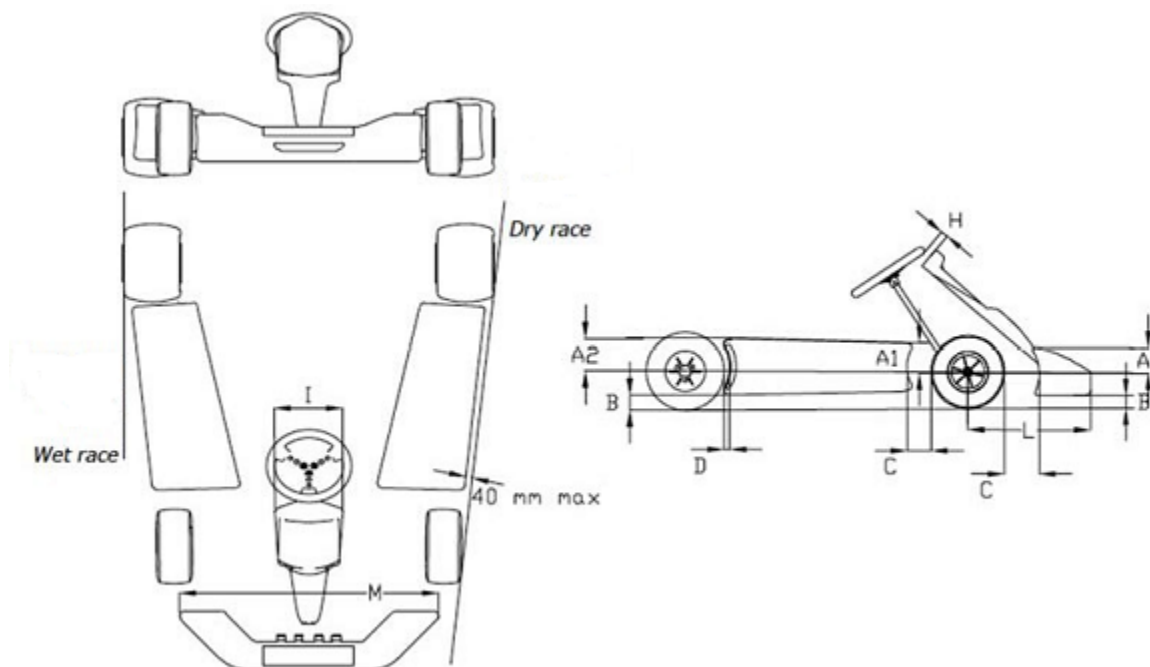

Code	Dimensions in mm	Limit	Comments
A1	Less than the front wheel radius		Front
A2	Less than the front wheel radius		Rear
B	25 - 60	Minimum - Maximum	Driver on board
C	150	Maximum	
D	60	Maximum	
H	50	Minimum	
I	250 - 300	Minimum - Maximum	
L	650	Maximum	
M	1000 - As Homologated	Minimum - Maximum	

27. Loose or Lost Components

All major bodywork components, rear protection, bumpers and chain guards shall remain in their normal

position throughout the competition.

Loose bodywork including side pods, front fairings (nose cone and steering column), rear protection, bumpers or chain guards may result in a fine or a kart being shown the BLACK flag with ORANGE DISK with kart number if judged by officials to be a hazard. A penalty may be applied even if the BLACK flag with ORANGE DISK cannot be displayed.

Loss of bodywork including front fairings (nose cone and steering column), rear protection, bumpers or chain guards will result in a kart being shown the BLACK flag with ORANGE DISK with kart number. A penalty will be applied even if the BLACK flag with ORANGE DISK cannot be displayed.

28. Mini60, OKJ, OK, KZ, KZ2 Class Preparation

Inspected according to CIK-FIA regulations.

29. Rok Mini, Junior, Senior, Shifter and Shifter Masters

Inspected according to Rok Cup Canada Regulations

http://www.vortex-rok.com/championship_engines.php?anno=2019&n=Canada&ID_campionato=40,61,98,120,128,172,237,269

32. Briggs & Stratton Cadet, Junior Lite, Junior, Senior and Masters

Inspected according to Briggs & Stratton Canadian Regulations

https://www.briggsracing.com/sites/default/files/content/files/briggs_2020_206_rules_canada_final.pdf

33. All Other Classes

Any other class not specified in these regulations will be inspected according to the official and accepted regulations published for that class or as specified in the Supplementary Regulations. Examples include World Formula, and IAME.

34. Fuel and Oil Requirements

34.1. Source and Communication

All classes may be required to use fuel for their specific classes, purchased from a specific source, for each sanctioned event. Communication of source shall be by bulletin at registration on the day of the event, and/or by Supplementary Regulation for the event.

34.2. Fuels Required for Certain Classes

Event variance may occur if accepted by the Technical Inspector. The Technical Director for the event may allow other specified fuels, which must be listed at the event.

- a. All Rok Cup Classes: Follows the Rok Cup Canada Regulations
- b. Four-Cycle classes are required to use Premium Unleaded gasoline with a minimum octane rating of 91 obtained from a specific location for each event.

34.3. Lubricant Oils

The chosen oil must be stated on the Competitor's entry form and declared by the competitor on the Pre-Technical Inspection Self-Declaration form. Any class may have a brand of oil specified for use in the Supplementary Regulations.

35. Fuel and Oil Testing

Fuel and oil testing at an event does not follow procedures or standards of laboratory testing.

36.1. General Conditions

Competitors are not entitled to a race fuel or oil check at any time, either for themselves or another competitor.

A fuel check may be taken at any time during the event, from any part of the fuel system.

A sample of engine lubricating crankcase oil may be requested at any time by the Technical Inspector. The Event Organizer may specify the use of any accepted method to determine fuel or oil legality.

36.2. Fuel Checking Procedure

When using a conductivity sensitive fuel probe, normal procedure is to dip the fuel tester probe into the competitor's fuel tank at any time during the entire event, to determine if the Competitor's fuel is within specification.

A test sample may be taken from the fuel line to the carburetor into a glass bottle and tested when:

- a. There is insufficient fuel in the tank. Insufficient fuel to test is defined as less than 10 fluid ounces
- b. There is insufficient access to the tank.
- c. The fuel level cannot be seen in the tank.
- d. Any other reason determined by the Technical Inspector.

Any additional test for gasoline and/or oil that is deemed acceptable by the Technical Inspector shall be admissible (i.e. specific gravity-hydrometer, additives-water test, chemical testing procedures etc.).

Decisions regarding fuel legality are not subject to protest.

36.3. Testing Four Cycle Fuel and Oil

The Technical Inspector may direct the Grid Marshal to order the start of all engines on the grid up to five (5) minutes before the class is allowed on the track.

For any qualifying session any competitor not present or not starting their engine at the appointed time, will start the first racing session at the rear of all other entrants.

For any racing session any competitor not present or not starting their engine at the appointed time, will start that racing session at the rear of all other entrants.

The Technical Inspector may require the change of fuel in a competitor's fuel tank at any time during the event.

37. Use of Cameras on Karts

37.1. Camera Mounting Positions Four-Cycle

- a. Upper fairing mount position - A second mount behind the existing one allowing for a camera to be positioned to face the driver.
- b. Lower fairing mount position - Below existing lower mounting hole on fairing.
- c. Rear seat mounting position - Must not protrude above top, below bottom plane of seat when viewed from the side in a level position.
- d. Left Side-pod mounting position
- e. Front Chassis mounting positions - Between a-bend and spindle mount. Mount must be metal with metal bolts and locking nuts or pinned/wired fasteners. Must not drop below lowest portion of frame rail. Must not interfere with pedals, feet, steering mechanism, spindle, or wheels and tires.

37.2 Camera Mounting Positions Two-Cycle

- a. Upper fairing mount position - A second mount behind the existing one allowing for a camera to be positioned to face the driver.
- b. Lower fairing mount position - Below existing lower mounting hole on fairing.
- c. Rear seat mounting position - Must not protrude above top, below bottom plane of seat when viewed from the side in a level position.

- d. Left Side-pod mounting position
- e. Radiator mount position
- f. Front Chassis mounting positions - Between a-bend and spindle mount. Mount must be metal with metal bolts and locking nuts or pinned/wired fasteners. Must not drop below lowest portion of frame rail. Must not interfere with pedals, feet, steering mechanism, spindle, or wheels and tires.

37.3 Camera Mounts







It is not permitted to mount a camera on a driver's helmet or body at any time.

Mounts must be from the manufacturer of the camera, be designed specifically for the camera, or be manufactured out of metal, be secured by a single bolt of no less than a quarter inch in diameter that is pinned/wired or secured with locking or pinned/wired nuts, or by a minimum of two 1/8 inch bolts that are pinned/wired or secured with locking or pinned/wired nuts.

Other mounting devices must be inspected at the track prior to use and be approved by the Race Director and Technical Inspector

Any camera and/or mount can be deemed ineligible at any time at the discretion of the Race Director and/or Technical Inspector. If a camera and/or mount is deemed ineligible it must be removed before the kart will be permitted back onto the track.

37.4 Permitted Cameras

Manufacturer	Notes	Mount Example	Sample Image
	<p>GoPro series cameras</p> <p>GoPro Roll Bar Mount</p> <p>MFR# GRBM30</p> <p>http://gopro.com</p>		
	<p>Replay series cameras</p> <p>Chassis Mount Kit</p>		



Drift series cameras



Drift Roll Bar Mount

<http://driftinnovation.com>



VIRB series cameras



GoPro Roll Bar Mount

MFR# GRBM30



Optrix by Body Glove



Optrix to GoPro Adapter

GoPro Roll Bar Mount

MFR# GRBM30

Discontinued



Aim SmartyCam series cameras



www.aim-sportline.com

Other Cameras

At discretion of Race Director and/or Technical Inspector