



2020 KartStars Canada Karting Championship Supplementary Regulations

August 20, 2020

A Kartsport Canada Series

Contents

1.	The KartStars Canada Karting Championship.....	3
2.	Kartsport Canada.....	3
3.	Series Inquiries	3
4.	Series Schedule	3
5.	Driver, Team and Parental Sportsmanship Theme	3
6.	Event and Championship Awards.....	3
7.	KartStars Pre-registration Discount.....	4
8.	2020 Points Chart.....	4
9.	Event Officials	5
10.	Regulations and Precedence of Regulations	5
11.	Amendment to Regulations.....	5
12.	KartStars Canada Karting Championship - Class Structure.....	6
13.	Wet Tires	6
14.	Race Tires	6
15.	Fuel Specification Briggs & Stratton Classes.	6
16.	Fuel Supply.....	7
17.	Fuel Specification All ROK Classes	7
18.	ROK Classes – Oil Spec	7
19.	Eligible Entries and License Requirements – All classes	7
20.	Competition Numbers.....	7
21.	Event Schedule.....	7
22.	Event Registration Fees	8
23.	Registration Process	8
24.	Paddock Spaces.....	8
25.	Restricted Areas.....	8
26.	Driver Briefings	9
27.	Number of Karts on the Race Track	9
28.	Eligibility to Race in a Pre-Final and Final Race	9
29.	Qualifying Procedures.....	9
30.	Standing Starts.....	9
31.	Transponders	9
32.	Marking of Engine and Tires	10
33.	Procedure at the End of Finals	10
34.	Official Notice Board.....	10
35.	Podium ceremony	10
36.	Organizers Claiming Rule.....	10

1. The KartStars Canada Karting Championship

KartStars Canada events are organized by Goodwood Kartways, Innisfil Indy Karting and Point Pelee Karting.

2. Kartsport Canada

The Series is authorized by Kartsport Canada

3. Series Inquiries

5200 2nd Concession, Stouffville, Ontario Canada - L4A 7X4 - (905) 640-5278 info@kartsportcanada.ca

4. Series Schedule

The series is a Four Round Championship.

Round 1	July 18-19	Goodwood Kartways, Stouffville, Ontario
Round 2	July 25-26	Innisfil Indy Karting, Innisfil, Ontario
Round 3	Aug 14-16	Goodwood Kartways, Stouffville, Ontario <i>*KartStars Canadian Karting Championship</i>
Round 4	Sept 5-6	Point Pelee Karting, Leamington, Ontario

5. Driver, Team and Parental Sportsmanship Theme

All participants, including entrants, drivers, crew members and parents/guardians shall conduct themselves according to the highest standards of behaviour and sportsmanship, particularly in relations with other competitors, officials, sponsors and their products, and in a manner that shall not be prejudicial to the reputation of the KartStars Canada Karting Championship, Kartsport Canada, promoters, sponsors, organisers, or to karting in general.

Sportsmanship means any person's conduct and behaviour while participating in a sport. Examples are fairness, respect for one's opponent, and graciousness in winning or losing.

Any abuse of officials or other participants will not be tolerated. Entrants, drivers and parents/guardians are responsible at all times for the conduct of their driver, crewmembers and guests. Any violation of this regulation is directly chargeable to the entrant and/or driver.

Yelling, shouting, physical altercations, bullying, intimidation either directly at an event or on internet social network programs are considered violations of this regulation.

Violation of this regulation can result in penalties including loss of Series points, driving privilege suspension, monetary fine, exclusion from a track session and/or the event and/or the KartStars Canada Karting series.

6. Event and Championship Awards

KartStars Trophies and Prizes — The top-3 finishers from each class, at all four races, will receive trophies. Top-3 finishers in KartStars Junior & KartStars Senior will receive a cash purse based on class entries.

Sunoco Race Fuels Sponsored Awards — Class winners of Mini Rok, Rok junior, Rok Senior and Rok Shifter will each be awarded a can of fuel at each event.

Vega Tires Sponsored Awards — One randomly selected Briggs class participant will win a set of Vega Blue ONT Racing Slicks at each round. One randomly selected Rok class participant will win a set of Vega Blue ONT Racing Slicks at each round.

Rok Cup Canada Sponsored Awards — Two randomly selected Rok class participants will win free entry to the next round.

Briggs and Stratton Sponsored Awards — Two randomly selected Briggs class participants will win free entry to the next round.

KartStars Canada Karting Championship Awards — The top three in each class will be awarded Championship trophies at the year-end banquet. Champions will receive coveted 'Class Champion Rings'

ROK Cup Canada Championship Awards — Class champions in Mini Rok, Rok Junior, Rok Senior and Shifter Rok will be awarded tickets to the Rok Cup SuperFinal in Lonato Italy. Masters tickets are available based on participation. Vice-champions in Mini Rok, Rok Junior, Rok Senior and Shifter Rok will be awarded tickets to the Rok the Rio in Las Vegas, Nevada. Masters tickets are available based on participation.

NewSpeed Motorsports Career Enhancement Award — Four drivers will be selected by a panel of judges throughout the four race series. The selected drivers will be invited to a test day where they will lap in a Nascar Pintys Series car owned and operated by New Speed Motorsports. The test will take place at Shannonville Motorsports Park on October 16th, 2020.

7. KartStars Pre-registration Discount

Registered Rok drivers will receive a 15% KartStars Canada pre-registration discount when buying Fuel and Oil through registration.

Registered drivers will receive a 15% KartStars Canada pre-registration discount when purchasing Race Tires through registration.

8. 2020 Points Chart

Points will be scored based on the official results of the Pre-Final and the Final for each race using the chart below. 25 bonus points will be awarded to the Pole winner in each class. The Canadian Championship Round (Round 3) will use the points below with a 1.5 multiplier. (Ex. A win is worth 300 points). There are no drops in the series.

Pre-Final

Position	Points Awarded	Position	Points Awarded	Position	Points Awarded
1	100	5	65	9	45
2	85	6	60	10	40
3	75	7	55	11	0
4	70	8	50	12	Cont'd

Final

Position	Points Awarded	Position	Points Awarded	Position	Points Awarded
1	200	11	85	21	35
2	175	12	80	22	30
3	155	13	75	23	25
4	140	14	70	24	20
5	130	15	65	25	15
6	120	16	60	26	10
7	110	17	55	27	5
8	100	18	50	28	0
9	95	19	45	29	0
10	90	20	40	30	Cont'd

9. Event Officials

Race Director/Steward:	Rob Oakman	Series Principal:	Daniel Di Leo
Clerk of the Course:	Jeff Conte	Registration:	Stefanie Di Leo
Starter:	Pierpaolo Petrucci	Timing and Scoring:	Maddie Luff
ROK Tech:	Rok Cup Canada	Scale Director:	Tim Sadchikov
Briggs Tech Inspector:	Bruce Fowler	Grid Marshall:	Alexander Chong

10. Regulations and Precedence of Regulations

The event will be run in accordance with:

2020 Kartsport Canada Karting Regulations

Book 1 Sporting Regulations

Book 2 Technical Regulations

Available at www.kartsportcanada.ca

ROK Regulations available at www.rokcupcanada.com

Briggs & Stratton Regulations available at www.briggsracing.com

The Regulations shall be as follows (in order of precedence):

- a) 2020 Kartsport Canada Karting Regulations.
- b) ROK Cup Canada and Briggs & Stratton Regulations.
- c) Kartsport Canada Bulletins.
- d) These Supplementary Regulations.
- e) Official KartStars Karting Canada Championship Bulletins.
- f) Instructions from Officials and on-site Bulletins.

Any claim of lack of knowledge of the Regulations will not be entertained.

11. Amendment to Regulations

When an event official schedule has started, amendments involving the Regulations and the event schedule can only be made by Kartsport Canada and the Series Chief Steward.

12. KartStars Canada Karting Championship - Class Structure

CLASS	WEIGHT	AGE	ENGINE	TIRES
Mini ROK	240 lbs	8 - 12	Vortex Rok	VEGA Blue ONT 4.6/4.6
ROK Junior	330 lbs.	12 - 15	ROK GP	VEGA Blue ONT 4.6/7.1
ROK Senior	360 lbs.	15+	ROK GP	VEGA Blue ONT 4.6/7.1
ROK Masters VLR	390 lbs.	30+ /200lbs+	VLR ROK	VEGA Blue ONT 4.6/7.1
ROK Shifter/Masters	385/405 lbs	15+	ROK SHIFTER	VEGA White ONT 4.6/7.1
BRIGGS Cadet	235 lbs.	7 - 11	LO206/RED	VEGA Blue ONT 4.6/4.6
BRIGGS JR Lite	265 lbs.	11 - 15	LO206/BLUE	VEGA Blue ONT 4.6/6.5
BRIGGS Junior	300 lbs.	12 - 15	LO206/GOLD	VEGA Blue ONT 4.6/6.5
BRIGGS Senior	340 lbs.	15+	LO206/BLACK	VEGA Blue ONT 4.6/6.5
BRIGGS Masters	375 lbs.	30+ /200lbs+	LO206/BLACK	VEGA Blue ONT 4.6/6.5
KartStars Junior	285 lbs.	11 - 15	LO206/GOLD	VEGA Blue ONT 4.6/6.5
KartStars Senior	360 lbs.	15+	LO206/BLACK	VEGA Blue ONT 4.6/6.5

13. Wet Tires

Wet tires for all classes will be VEGA ONT W5 or VEGA ONT W6. Drivers must use 4.60 fronts and 6.50 rears in wet conditions except for Mini Rok and Briggs Cadet which will use 4.60 fronts and rears.

14. Race Tires

All Shifter Classes:

Drivers must use Vega White Ont branded tires. Drivers must purchase one set from the designated tire distributor during pre-registration an option to purchase a second set will be permitted. Those two sets of tires must be used for the entire weekend. A KartStars discount of 15% off the first set of Race Tires will be available at the time of pre-registration. All tires must be declared on the tech sheet.

All Other Rok classes:

Drivers must use Vega Blue Ont branded tires. Drivers in Rok Shifter will use Vega White Ont branded tires. Drivers must purchase one set from the designated tire distributor during pre-registration. That one set of tires must be used for the entire weekend. A KartStars discount of 15% off Race Tires will be available at the time of pre-registration.

All Briggs classes:

Drivers must use Vega Blue Ont branded tires. Drivers can bring their own NEW or USED Race Tires as long as they meet class specifications. A KartStars discount of 15% off Race Tires will be available at the time of pre-registration for drivers who choose to buy NEW tires through registration.

15. Fuel Specification Briggs & Stratton Classes.

Fuel used by the participants must comply with the 2020 Kartsport Canada Karting Regulations.

- The spec fuel for **Goodwood Kartways** events is ESSO Supreme:

Fuel must be purchased at one of the following locations.

ESSO in Stouffville, on the south/west corner of Bloomington Rd (#47) and Markham Rd (#48).

- The spec fuel for **Innisfil Indy Karting** events is Ultramar Supreme:
Fuel must be purchased at Ultramar 2231 Simcoe 89, Gilford, ON L0L 1R0
- The spec fuel for the **Point Pelee Karting** events is Circle K 91:
Fuel must be purchased at Circle K 2 Seacliff Dr. W Leamington, ON N8H 2L4

16. Fuel Supply

It is the driver's responsibility to have fuel for each event.

17. Fuel Specification All ROK Classes

The spec fuel for ALL Rok classes is Sunoco 110 which will be available at all venues. A KartStars discount of 15% off Race Fuel will be available at the time or pre-registration.

18. ROK Classes – Oil Spec

All Rok classes will use Silkolene Pro KR2, PRO2 or Motul 2T as the spec oil. A KartStars discount of 15% off Race Oil will be available at the time of pre-registration.

19. Eligible Entries and License Requirements – All classes

a) Residents of Canada

Canadian residents must be members in good standing of any recognized Canadian Karting club. They may enter any KartStars Canada Karting Championship Class provided the driver meets the entry qualifications for their particular class, and their kart meets the appropriate technical requirements.

b) Residents of the USA

For all classes, residents of the USA must possess a current and valid licence/membership issued only by the World Karting Association or equivalent.

c) Foreign Drivers

Foreign drivers are non-Canadian and non-USA drivers and must possess a current and valid National Licence issued by the ASN of their home country. In addition, the driver must present a Letter of Permission issued by the ASN of their home country authorizing them to compete.

20. Competition Numbers

All karts must have a unique number of three digits made up of numerals only except Briggs & Stratton Cadet. The first digit in each three-digit number must correspond to the table below. No letters will be allowed. In instances of conflicts the Kartsport Canada National number registry will take priority, then the hosting track's Club, then the affiliated Clubs and finally visitors.

Numbers	Class	Numbers	Class
102-199	ROK Mini	2-99	Briggs & Stratton Cadet
202-299	ROK Junior	102-199	Briggs & Stratton Junior Lite
302-399	ROK Senior	202-299	Briggs & Stratton Junior
402-499	ROK Masters	302-399	Briggs & Stratton Senior
502-599	ROK Shifter & Shifter Masters	402-499	Briggs & Stratton Masters

21. Event Schedule

Event schedule will be posted online and available at the track before each event.

22. Event Registration Fees

The registration fees for the classes are outlined in the table below. Drivers are only eligible for the KartStars Classes if they are racing in their National Briggs class as well. Entry includes 1 driver pass, 1 mechanic pass, 20x30 paddock space. Transponder rentals are available at \$10 fee, if needed.

Fee	Class	Fee	Class
\$150 + HST	ROK Mini	\$150 + HST	Briggs & Stratton Cadet
\$225 + HST	ROK Junior	\$150 + HST	Briggs & Stratton Junior Lite
\$225 + HST	ROK Senior	\$150 + HST	Briggs & Stratton Junior
\$225 + HST	ROK Masters	\$150 + HST	Briggs & Stratton Senior
\$225 + HST	ROK Shifter & Shifter Masters	\$150 + HST	Briggs & Stratton Masters
\$75 + HST	KartStars Junior*	\$75 + HST	KartStars Senior*

**KartStars Junior discounted registration fee of \$75 available only to drivers who register in either Briggs Junior Lite or Briggs Junior. KartStars Senior discounted registration fee of \$75 available only to drivers who register in either Briggs Senior or Briggs Masters.*

23. Registration Process

- a) Online registration opens approximately 14 days prior to event date and close the Thursday night prior to the event at 8 pm. After the closing of the online registration, only onsite registration will be possible.
- b) For onsite registration, a \$25.00 administrative fee will apply per driver. Payment types include cash, credit, debit or cheque.
- c) Participant Info. – All participants and crew members must read and sign a waiver form. No participant will be allowed to practice on Friday until they have registered for the event.
- d) At Registration, each participant must submit a fully completed Pre-Technical Inspection Self-Declaration form. Registration will issue the appropriate kart sticker only after the payment of event fees and completion of all required paperwork.
- e) Drivers found on the track without having completed the approved Pre-Technical Inspection Self-Declaration form are subject to penalty.
- f) All karts must bear the appropriate kart sticker and kart number before entering the track.
- g) It is the competitor's responsibility to ensure that their kart meets the technical requirements for their class throughout the entire race event.
- h) Any kart or driver's racing equipment is subject to Technical Inspection at any time.
- i) Entry fees are non-refundable. Refunds will be entertained for extenuating circumstances.

24. Paddock Spaces

Contact hosting facility to make arrangements.

25. Restricted Areas

The racetrack infield, the perimeter of the track, the Pit Lane, Pre-Grid, Grid, Scale Area and Technical Inspection areas are restricted areas.

Access to the Grid and Pit Lane is available only to participants when their class is running. One crewmember with a Mechanic's Pass is allowed on the Grid with each entry.

A Hot Pit will not be used during practice, qualification sessions or races.

Holders of Passes including team members and guests are entitled free access to the paddock and spectator areas only.

26. Driver Briefings

Drivers must attend the driver briefing on any day when they are required to be on the racetrack. A presence control or role call may occur. Drivers who are not present during drivers briefing may be penalized with the loss of fastest lap in qualifying.

27. Number of Karts on the Race Track

A maximum of 34 karts will be allowed to start in a Final at all races. The Race Steward may alter the maximum number at all Rounds.

28. Eligibility to Race in a Pre-Final and Final Race

All entries must participate in qualifying for their class. A driver who has not competed in Qualifying will start all Heats in the rear.

All entries must participate in the Heats. A driver who has not competed in the Heats, will start the Pre-Final at the rear.

All entries must participate in the Pre-Final for their class. A driver who has not competed in the Pre-Final, will start the Final at the rear.

The qualifying positions will set the grid for the Heats.

Points accumulated from Qualifying, Heat 1 and Heat 2 will determine the starting grid for the Pre-Final.

The finishing positions in the Pre-Final will determine the starting grid for the Final.

The finishing positions in the Pre-Final and Final will be used to assign points and for daily awards.

29. Qualifying Procedures

For qualifying sessions, drivers may be split into two groups depending on the size of the group. Drivers are required to be ready on the grid before their designated group session.

Qualifying results may be equalized at the discretion of the Race Director and/or Steward(s) if they are affected by changing weather conditions or force majeure.

Late drivers will not be permitted to enter the track and thus unable to set a qualifying time and will start the Heats at the rear.

A driver can only enter the track when designated by the grid marshal. Sessions will be timed as per the event schedule.

30. Standing Starts

For classes that utilize a standing start, grid positions at Innisfil Indy Karting will use a staggered alignment.

31. Transponders

Each kart must be equipped with a transponder mounting bracket. The transponder must be installed according to AMB / Mylaps instructions.

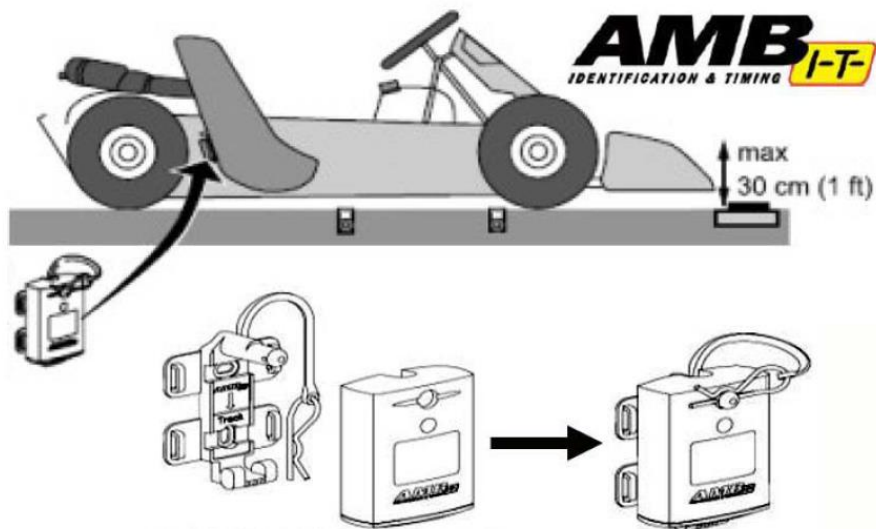

Event organizers will not have transponders for rent. Transponders may be rented from a third party. It is recommended that competitors purchase their own transponder.

Neither the Organizer or the Officials are responsible for any transponder failure during the event.

Drivers must register their transponder number, either their own or rented from a third party, on the entry form or at the latest the time of the onsite event registration.

32. Marking of Engine and Tires

Engines and tires will be marked either manually or electronically, before or after qualification sessions. It is the driver's responsibility to be sure that their engine and tires are marked before leaving the area where the engine and/or tires are marked. Race tires must be declared on the self declaration technical inspection form.

33. Procedure at the End of Finals

The top five (5) finishers in each Final race in each class will proceed to the Parc Fermé and remain there until released by Technical Officials.

34. Official Notice Board

The Official Notice Board location will be designated at each event.

35. Podium ceremony

Prizes and trophies winners must be present to the podium ceremony wearing their racing suits, closed and zipped. If a driver cannot attend the podium ceremony for a good reason, he must inform the Steward before the ceremony. Racers who miss the podium presentation without cause MAY forfeit series prizes and awards. Podium presentations will take place at the conclusion of each race day.

36. Organizers Claiming Rule

In order to maintain a level playing field for members and guests, there is a CLAIMING RULE FOR ALL CLASSES.

Competitors making a claim at an event must be entered in the affected class. They may only claim an engine within their entered class with a maximum of two claims throughout the calendar season. A competitor, or representative thereof, cannot claim their own engine. A claimed engine CANNOT be re-claimed by the original owner in the same season.

The competitor making a claim must give written notice to the Event Organizer prior to the display of the chequered flag of the class final race and must include payment in full.

The price, payable to Goodwood Kartways, to claim an engine in a Briggs class is as follows:

\$825.00 – replacement cost
plus a \$150.00 transfer fee,
plus a \$225.00 administrative fee,
Total - \$1,200.00 plus HST.

The price, payable to Goodwood Kartways, to claim an engine in a Rok class is as follows:

\$3,800.00 – replacement cost
plus a \$500.00 transfer fee,
plus a \$500.00 administrative fee,
Total - \$4,800.00 plus HST.

There can only be one claim on an engine at an event. The first fully completed claim is the only claim. The Organizer will hold the claim money until the claimed engine has been inspected for legality. Inspection of claimed engine is according to class regulations and MAY NOT be waived by any party.

The claimed engine will be tagged as soon as it comes across the scales and will be immediately taken to the Organizer for inspection and remain in Organizer's possession throughout the entire process. Both claimer and claimed have the option to be present at the time of inspection. The decision by the Organizer Technical director is final and binding and no further action can be taken by any party.

If the claimed engine is found to be legal:

The claimed engine will be awarded to the claimer.

The claimer will receive any and all items which are found in the originally packaged product.

All external components are subject to inspection but will be returned to the claimed party.

Goodwood Kartways will award the claimed party w/ a NEW engine in a factory sealed box, plus a corresponding transfer fee.

If the claimed engine is found to be illegal:

The Organizer Tech Director must confiscate ALL illegal parts and related parts from the claimed engine.

The Claimer has the option to void the claim if engine is found illegal and claim money less the administrative fee will be returned to the person filing the claim.

Refusal of claim, destroying or withholding of parts, or any other lack of cooperation in this claim or inspection process will be interpreted as an admission that the engine is illegal and may subject the driver to further penalties.

The officials may alter the procedure without prior notice in exceptional circumstances

This Claiming Rule is subject to change at the discretion of the Organizer. Any change in this rule will be posted on-line in accordance with our Rules and Regulations.